

## Treason at the CIA

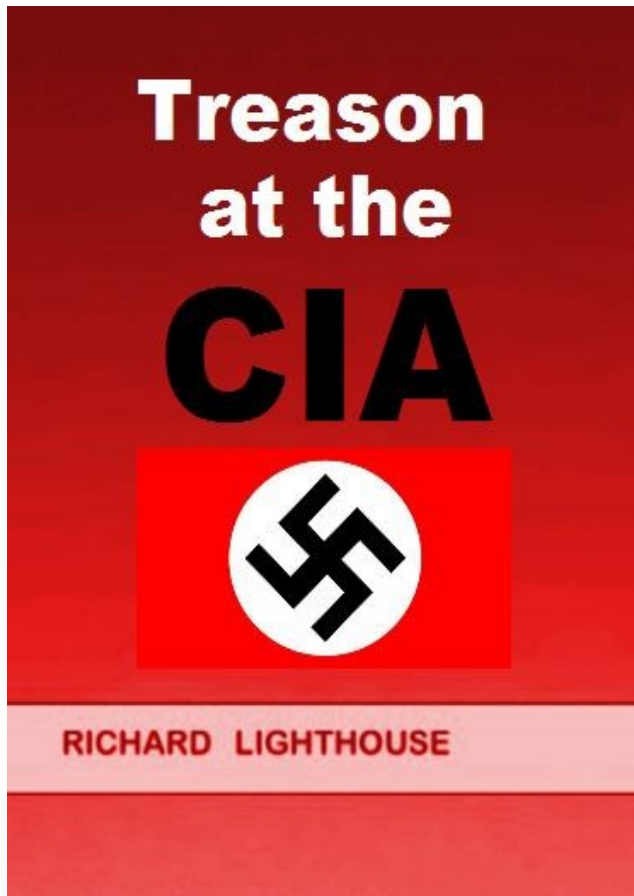

Richard Lighthouse

Treason at the CIA

Published by Richard Lighthouse at smashwords.com

Copyright © 2017 by Richard Lighthouse. All rights reserved.

ISBN: 9781370074303

<https://www.smashwords.com/books/view/732090>

No part of this publication may be reproduced, stored in a retrieval system, or transmitted in any form or by any means, electronic, mechanical, photocopying, recording, scanning, or otherwise, except as permitted under Section 107 or 108 of the 1976 United States Copyright Act, without the prior written permission of the Copyright holder.

Limit of Liability/Disclaimer of Warranty: While the author has used his best efforts in preparing this document, he makes no representations or warranties with respect to the

accuracy or completeness of the contents and specifically disclaims any implied warranties or fitness for a particular purpose. No warranty may be created or extended by sales representatives or sales materials. The author shall not be liable for any loss of profit or any other commercial damages, including but not limited to incidental, special, consequential, or other damages.

#### NOTE TO GOVERNMENT AGENCIES AND THEIR CONTRACTORS:

Theft of Intellectual Property and violation of copyright is a serious matter. Under no circumstances did the author consent to such criminal activity. Attempts to conceal criminal activity is even more serious, which may result in charges of Felony Fraud and/or Felony Conspiracy. The author does not license any material for groups or organizations.

#### About the Author:

Many of my books can be found for FREE at: Apple iBooks, Amazon.com, Lulu.com, Smashwords.com, BarnesandNoble, Google Play, kobo, and other websites.

Original 1A – 24 June 2017

Houston, Texas, U.S.A.

Revision 2A– 7 July 2017

“The world will not be destroyed by those who do evil, but by those who watch them without doing anything.” - Albert Einstein

### TABLE OF CONTENTS

#### **Chapter 1:**

##### [Introduction](#)

#### **Chapter 2:**

##### [Conclusions](#)

#### **Chapter 3:**

##### [References](#)

##### [Abstract](#)

Rev 2A. This author has been investigating satellite weapons and the global microwave torture of thousands of people, since January 2016. This ebook contains some of my latest research into Targeted Individuals. The CIA is operating a program against its own civilians and top government officials that is nothing less than TREASON. They are attempting to control top government people using a subliminal messaging technology, including the legislative, executive, and judicial branches. This includes the President and White House cabinet. The technology is not 100% effective, but it works well enough to alter behavior after many months of microwave targeting with subliminal messages. I have referenced a number of credible sources including, Dr Barrie Trower, a retired British intelligence agent; Dr John Hall, M.D. In San Antonio; and Dr Katherine Horton, an Oxford scientist. Their videos are available on youtube. This follows the documented TREASON by the CIA in Michael Springmann's new book.

Michael Springmann is the former head of the American visa bureau in Jeddah, Saudi Arabia. While stationed in Saudi Arabia, Springmann was repeatedly ordered by the CIA and State Department officials to issue visas to terrorists, prior to 9-11. Springmann objected repeatedly, complaining to his superiors that the applicants were known terrorists. 19 of these visas became the 9-11 hijackers. Springmann filed numerous complaints with his superiors, he wrote to Senators and Congressmen, and was eventually fired by the State Department because he would not be silenced. It is clear that the CIA planned 9-11 from the beginning.

After extended discussions with three personal contacts, I can state that the use of satellite microwave weapons on civilians is definitely occurring. This is happening to thousands of people all over the world, which has been well-documented by John Finch. It is an extension of the illegal CIA MK-Ultra program, which was ordered to be shutdown by the Frank Church Committee hearings in the 1970's. Based on this research, I can state with complete confidence that Ed Snowden and Julian Assange are also microwave targets of this illegal program. Their family members are targets of the subliminal messaging program, which is intended to isolate them emotionally. The microwave beams are painful and cause permanent damage. It is nothing less than torture, and it is banned under international treaties. It is a serious violation of Constitutional rights, it is defined as a war crime by international treaties, and when conducted against US citizens and top government employees, it is nothing less than TREASON. Let me be clear – the CIA is operating a program against top government officials and U.S. citizens that is nothing less than TREASON. They are attempting to control the government, including the legislative, executive, and judicial branches of our government. See my related ebook, “34 Patents on Subliminal Mind Control.”

These satellite frequencies are being used in a subliminal messaging program against Targeted Individuals and their family members, in an attempt to control their behavior. The CIA is also using these same frequencies and subliminal messaging to alter the behavior of key government employees, such as Senators, Congressmen, and even the President and his cabinet. This is TREASON. The microwave and RF technology to alter behavior has been well-documented. I have previously documented the frequencies as follows: Tracking and geolocation: approx. 3600 MHz to 3750 Mhz, and the carrier frequency for the subliminal messaging and harm signals has been measured at 3921 MHz – 3934 MHz. The subliminal messaging is repeated thousands of times each night on the target, until the negative

messages “stick.” These messages can be simple - “Your husband is crazy,” or “You hate him.” Recall that CIA Doctor Ewen Cameron used these subliminal techniques to turn an ordinary person into a vicious serial killer – the real Manchurian Candidate, as part of the CIA's MK-Ultra program. Mike Pompeo, current CIA Director is fully aware of these programs. This is obvious from the reorganization of the CIA's field agents, into remote monitoring of targets, which were exposed with the Vault 7 wikileaks files. Many senior managers at the CIA are fully aware that the President and his cabinet are being targeted with subliminal messages. These CIA criminals should be charged with high TREASON and tried before a public court.

The recent Vault 7 files also include emails from the Stratfor Corporation, with employees joking about Microwave Torture – clearly they know what is going on. The executives of Stratfor should be charged with war crimes and TREASON.

The satellites that are being used were launched as part of President Reagan's Star Wars program, and are designed to track and hit ballistic missiles with a microwave beam that disables the missile's navigation system. If these satellite systems can track a missile at 10,000 miles per hour, they can easily track a person, or many persons simultaneously on the ground. Technical details of this illegal torture program are provided. It is important that Mr Snowden and Mr Assange come forward with statements objecting to these illegal programs. The criminals in the CIA and their supporting organizations can be charged with war crimes and crimes against humanity. The recent release of the Vault 7 files through wikileaks makes it clear that government contractors, such as the Stratfor company in Austin, Texas are also part of this criminal organization. The criminal activities of the CIA are a domestic threat to the U.S. Constitution - the CIA must be abolished. These government employees work under a sworn oath, defending the U.S. Constitution against all enemies, foreign and domestic - it is time to exercise that oath.

The CIA and FBI are "behind most, if not all terrorism." - Ted Gunderson, former FBI Chief

## **Introduction**

On 18 January 2017, the following appeared in Pravda, which is the official government newspaper in Russia:

[http://www.pravdareport.com/opinion/columnists/18-01-2017/136653-open\\_letter\\_trump-0](http://www.pravdareport.com/opinion/columnists/18-01-2017/136653-open_letter_trump-0)

"And, information that seems much stranger than fiction is covered in books and videos such as "Targeted Individuals" by Richard Lighthouse. This book describes modern-day sophisticated attacks against individuals which experts say can cause heart failure and other fatal or debilitating results. Lighthouse bases his book on information and testimony from such investigators as Dr. Barrie Trower, retired British military scientist, author Dr. John Hall M.D., and Oxford-educated scientist, Dr. Katherine Horton, among others. NSA whistleblowers William Binney and Kirk Weibe recently announced their support for "Targeted Individuals." In other words, there are more ways to hurt or kill a President or political leader than by a bullet."

It is clear that the Russians and other intelligence agencies are aware of the CIA's criminal

activity, but do not know how to defend themselves. This targeting of individuals is happening all over the world. In spite of some reports that this is part of an “experiment” - this is the lie and cover story that is used with the military and Pentagon officials. The targeting is not simply random – it is used against anyone that is opposed to government policies and agendas, which are promulgated by the Deep State and Shadow government. These entities are funded and backed by the Rockefeller and Rothschild families. See my ebook about the hidden assets of the Rockefeller's and Rothschild's.[7]



Figure 1. Typical Spectran HF-4040 reading taken in summer 2016. 3648 MHz at -71dbm and 3921 MHz at -59 dbm. There are very few users in this frequency range – so it is easy to identify. 3648 MHz is used for tracking and 3921 MHz is used for the harm frequency and as a carrier wave for subliminal messaging. The FCC table confirms that these frequencies have been reserved for satellite to ground signals.

Table of Frequency Allocations					3500-5460 MHz (SHF)	Page 41
International Table			United States Table		FCC Rule Part(s)	
Region 1 Table (See previous page)	Region 2 Table	Region 3 Table	Federal Table	Non-Federal Table		
	3500-3700 FIXED FIXED-SATELLITE (space-to-Earth) MOBILE except aeronautical mobile Radiolocation 5.433	3500-3600 FIXED FIXED-SATELLITE (space-to-Earth) MOBILE except aeronautical mobile 5.433A Radiolocation 5.433	3500-3550 RADIOLOCATION G59 AERONAUTICAL RADIONAVIGATION (ground-based) G110	3500-3550 Radiolocation	Private Land Mobile (90)	
3600-4200 FIXED FIXED-SATELLITE (space-to-Earth) Mobile		3600-3700 FIXED FIXED-SATELLITE (space-to-Earth) MOBILE except aeronautical mobile Radiolocation 5.433	3550-3650 RADIOLOCATION G59 AERONAUTICAL RADIONAVIGATION (ground-based) G110	3550-3600 FIXED MOBILE except aeronautical mobile US105 US433 3600-3650 FIXED FIXED-SATELLITE (space-to-Earth) US107 US245 MOBILE except aeronautical mobile	Citizens Broadband (96)  Satellite Communications (25) Citizens Broadband (96)	
		5.435	US105 US107 US245 US433 3650-3700 FIXED	US105 US433 3650-3700 FIXED FIXED-SATELLITE (space-to-Earth) NG169 NG185 MOBILE except aeronautical mobile		
	3700-4200 FIXED FIXED-SATELLITE (space-to-Earth) MOBILE except aeronautical mobile		US109 US349 3700-4200	US109 US349 3700-4200 FIXED FIXED-SATELLITE (space-to-Earth) NG180	Satellite Communications (25) Fixed Microwave (101)	
4200-4400 AERONAUTICAL RADIONAVIGATION 5.438 5.439 5.440 4400-4500 FIXED MOBILE 5.440A 4500-4800 FIXED FIXED-SATELLITE (space-to-Earth) 5.441 MOBILE 5.440A			4200-4400 AERONAUTICAL RADIONAVIGATION 5.440 US261 4400-4940 FIXED MOBILE	4400-4500  4500-4800 FIXED-SATELLITE (space-to-Earth) 5.441 US245	Aviation (87)	

Figure 2. FCC frequency assignments, yellow highlights for the targeting frequencies. Only the Clowns, Idiots, and Assholes (CIA) would establish a written program that identified the frequencies they were using, and then use a Psyop program to deny it. The CIA is the laughing stock of the intelligence world. How can the CIA managers of this program remain employed?

[transition.fcc.gov/oet/spectrum/table/fcctable.pdf](https://transition.fcc.gov/oet/spectrum/table/fcctable.pdf)

The FBI has previously tried to provide disinformation on these frequencies by releasing information suggesting that Extremely Low Frequencies (ELF) are behind the subliminal messaging. This was done with the Aaron Alexis murders, by carving "ELF weapon" into the gun. He had no technical knowledge to suggest this was the correct frequency. Anyone with an advanced degree in physics or engineering can explain that an ELF frequency of 1 to 30 Hz, cannot carry a voice signal of 500 to 1000 Hz. It is literally impossible. Only the Clowns, Idiots, and Assholes would use a Psyop explanation that violated laws of physics.



*A close-up photograph of the etchings on the left side of Alexis' shotgun receiver. Photo and caption released by the FBI*

Figure 3. FBI photo of the gun used by Aaron Alexis. Aaron complained of microwave harassment. Aaron had no technical training on frequencies or the physics of ELF waves. The only rational explanation, is this weapon was marked by FBI agents. Fabrication and alteration of evidence is a felony crime. The FBI did this to provide disinformation on what is causing the microwave voices. The actual frequency that is used, is a carrier wave of approx. 3921 MHz, and it is broadcast from a satellite. ELF waves of 1 to 30 Hz cannot carry a voice signal of 500 to 1000 Hz. It is impossible.

In 1995, President Bill Clinton answered a question about a campaign promise he had made – to get to the bottom of the UFO mystery. His answer was, “There is a government within our government, and I do not control it.”

John Podesta was President Clinton's Chief of Staff. He also worked in President Obama's administration and under Hillary Clinton when she ran for President. Many of his emails were released through wikileaks, including one which identifies the Shadow Government as operating under the Secretary of State (John Kerry) and having offices on the 7<sup>th</sup> subfloor of the Truman Building in Washington D.C. The Shadow Government is real and is openly discussed by the White House staff. In my opinion, these people report to the Council on Foreign Relations, where many of them are members, and which was headed for years by David Rockefeller.

but none were deemed a B(1) exemption. Most of the items with CIA redactions were emails from Sidney BLUMENTHAL. One item was deemed classified according to the FBI and KENNEDY held a closed door meeting attended by the FBI's \_\_\_\_\_ and IPS' \_\_\_\_\_ among others. In that meeting, KENNEDY asked \_\_\_\_\_ to change the FBI's B(1) upgrade classification, but \_\_\_\_\_ did not change the FBI's stance. On May 22, it was decided by the IPS team they would keep the upgrade of the one FBI-related email and the IPS officials sent David KENDALL, Attorney, Williams & Connolly, LLC, a letter informing him of the results.

There was a powerful group of very high-ranking STATE officials that some referred to as "The 7<sup>th</sup> Floor Group" or "The Shadow Government." This group met every Wednesday afternoon to discuss the FOIA process, Congressional records, and everything CLINTON-related to FOIA/Congressional inquiries. The known regular attendees included Jonathan FINER, Chief of Staff for Secretary of State John KERRY, Jennifer STOUT, Deputy Chief of Staff, Heather HIGGINBOTTOM, Deputy Secretary of State for Management and Resources, KENNEDY, Julia FRIFIELD, Assistant Secretary, Legislative Affairs, \_\_\_\_\_ Office of the Legal Adviser, \_\_\_\_\_ Office of the Legal Adviser overseeing STATE's \_\_\_\_\_, \_\_\_\_\_ and \_\_\_\_\_.

Normally, with larger FOIA requests, such as with the CLINTON-related FOIA request, IPS would schedule a rolling release----that meant every few weeks or month, the properly reviewed and approved material would be made public. However, \_\_\_\_\_ and The 7<sup>th</sup> Floor Group argued the release should be done all at once in January 2016, for coordination purposes. While IPS officials did not have control of the release process of the 296 emails related to the House Select Committee on Benghazi's request, they did have control for the release process for the approximately 30,000 emails, or 52,455 pages related to the CLINTON FOIA request, and it was decided to be a rolling release.

Figure 4. From FBI.gov – the State Department houses the Shadow Government on the 7<sup>th</sup> subfloor of the Truman Building in Washington D.C. White House staff openly discuss the Shadow Government. The current Secretary of State is Rex Tillerson, who was previously the CEO of ExxonMobil Corporation. John Rockefeller was the founder of the Exxon Corporation, and the Rockefeller family holds a controlling interest in the company.

The Rockefellers and Rothschilds are the hidden owners of the Federal Reserve Bank in New York City. This is another criminal enterprise which must be abolished. As they always say, to find the criminal source, "Follow the money."

How can we be certain the CIA is behind these criminal acts? Because under Presidential Executive Order 12333, only the CIA may act on foreign intelligence information, such as Julian Assange. He is not a U.S. Citizen, and he is not located in the U.S.

The US Military is prohibited by law from targeting US citizens with PSYOPS within US borders under Executive Order S-1233, DOD Directive S-3321.1 and National Security Directive 130. Again, this further implicates the CIA and FBI for these criminal acts, because many of the Targeted Individuals are located in the United States.

Government agents may NOT classify information or materials in order to hide their criminal acts. This may have been done under a National Security Letter, in violation of a Presidential Executive Order. Order 13526, section 1.7 specifically states, "In no case shall information be classified...to conceal violations of law, inefficiency, or administrative error; or to prevent



*embarrassment to a person, organization, or agency.*” Over 300,000 NSL’s (National Security Letters) have already been issued in the United States.

Previous Executive Orders covering national classified information:

Executive Order 10290 (September 24, 1951; Harry S. Truman)  
Executive Order 10501 (November 5, 1953; Dwight D. Eisenhower)  
Executive Order 11652 (March 8, 1972; Richard Nixon)  
Executive Order 12065 (June 28, 1978; Jimmy Carter)  
Executive Order 12356 (April 2, 1982; Ronald Reagan)  
Executive Order 12958 (April 17, 1995; Bill Clinton)  
Executive Order 13292 (March 21, 2003; George W. Bush)

Susan Lindauer, NSA whistleblowers William Binnery and Kirk Weibe announced their support for Targeted Individuals. Keep in mind, when the CIA or FBI target an individual, they also target their entire family and close friends using the same frequencies to bombard the family members with subliminal messages. There are a number of government patents that document the capabilities of these subliminal messaging systems. See my ebook “34 Patents on Subliminal Mind Control.” Basically, the targeting is designed to destroy the personal family relationships – in all cases the person is isolated and alienated by the changes in their family. The targeting of the family members starts, even before they begin the microwave torture of the individual. Again, the frequency that is being used for subliminal messaging is about 3921 to 3934 MHz, and the voltage is very low, less than 1 millivolt. The family members are not aware they are being targeted, unless they measure it with a voltmeter. A signal analyzer can be used to determine the frequency.

The organizational structure of the CIA has been changed. They are removing most field personnel from exposure in international countries. This makes no sense in the intelligence industry because human intelligence gathering (hum-int) has been thought to be a critical piece for any intelligence organization. However, they are using remote technologies - cyber weapons on computers and microwaves to target people on the ground. EEG heterodyning, which is an artificial form of telepathy is also used – more on this in an upcoming ebook. Some of the research for artificial telepathy was done at UC Irvine. The key to this is - All of this technology is done remotely. The technology is real and has been described to me in detail by two credible sources, and discussed in detail by hundreds of people in the notes of John Finch (search for “John Finch” Australia, TI). The CIA would have no need for more agents in the field, just more satellites to target people. These methods are now being used by the CIA as an act of TREASON against our own government.

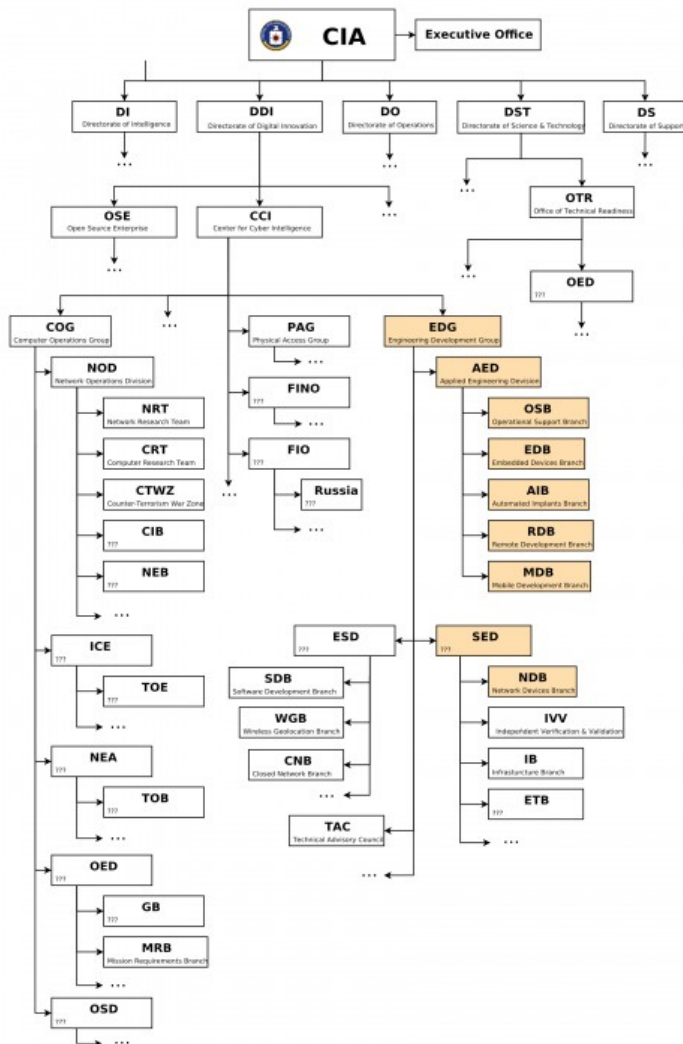

Figure 7. CIA organization chart developed from the Vault 7 wikileaks files. Most of the operations are now done remotely - Cyber weapons from computers and microwaves from satellites.

They are using these technologies to target key government officials, including members of the Senate and Congress, the White House, and the Supreme Court. It is TREASON, pure and simple. And Pompeo knows it. The lie that is told to the Pentagon and the military is – this is a technology experiment. The lie is different at every level. The technology is being used to control people and alter their decisions, including the President.

Did you notice the vast change in President Trump's policies that started happening in April 2017? That was 5 months after he was elected. We can deduce that it took 5 months of targeted subliminal messages to get him to adopt some of the policies of the Deep State. It is not simply an experiment. The same thing was done to President Obama. Based on Obama's deep socialist background, there is no rational basis for him to promote and champion the Trans-Pacific Partnership (TPP) – which was a massive corporate giveaway, benefiting the Rockefellers and Rothschilds. Never in Obama's writing has he proposed

giving corporate control over state governments. It just doesn't add up.

The protection from this subconscious assault is simple – because it starts with attacking the subconscious mind. A simple repeated statement at bedtime is particularly effective – "I will only react to constructive suggestions." This programs your subconscious mind to filter and block negative messages.

For those readers that are not familiar with Ted Gunderson, I recommend a review of some of his heroic work.

The CIA and FBI are "behind most, if not all terrorism." - Ted Gunderson, former FBI Chief

So how does the technology work? How are they able to find someone to target specific points on their body.



Figure 5. Microwave Targeting. A grid pattern of microwave shots or “bullets” is used and the reflected signal tells them exactly where you are and how you are positioned. This can be done in a matter of seconds using the satellite, and is particularly easy if the target is still or sleeping. It even works thru many stories in an apartment building – because the reflected signal is very unique when it hits a person. If a mylar sheet is placed above the person, you can actually hear the microwave shots hitting the mylar sheet. (a microphone recording can be made this way with the sound amplified.) The satellite's tracking signal can shoot more than 20 times per second – and the frequency is about 3600 to 3700 MHz. They can track many people at the same time with one satellite.

The National Reconnaissance Office (NRO) and the National Geospatial - Intelligence Agency (NGA) are two of the classified agencies that design and build satellites for tracking and locating anything on the ground. These government criminals know exactly what their designs are being used for – and they should be prosecuted for war crimes.

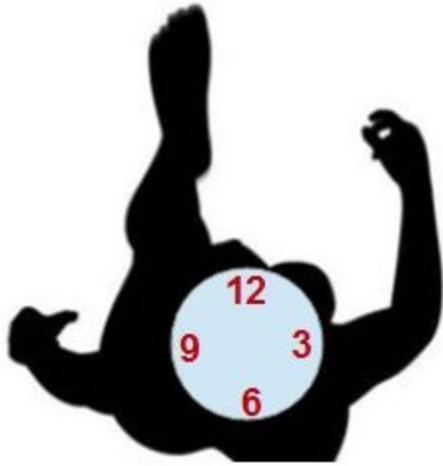

Figure 6. How does it track someone walking around? (This technology is described in general terms here, as the specific capabilities and limits of the tracking are not known) Your skull bone makes an excellent reflector of a microwave beam. The reflected signal can be tracked by using a pattern of the top of your head. The tracking signal frequency at 3640 MHz, bounces a signal off the person's head in 4 or more locations – we will use 12, 3, 6, and 9 as an example. This tracking signal is shot many times each second, so when the person moves, the motion is detected by an absent reflection and the aim is adjusted accordingly. The harm signal is always aimed at the center of the last 4 coordinates – so it always stays centered. As a harm signal, the voltage on the head varies from about 1 millivolt to 10 millivolts, with 10 being extremely painful.



Figure 7. Analog multimeter available for under \$10. Attach the ends to a strip of aluminum foil and it will detect voltages in the range of 0.5 to 10 millivolts. There should not be voltage readings like this anywhere on your body, for any reason. A signal analyzer can identify the frequency that is being used. Some are available at [windfreak.com](http://windfreak.com) (I do not work for or endorse any of their products. These devices can be purchased from many different manufacturers.)

I was informed that persons located far north or south, i.e. closer to the poles, are not tracked with the same precision. This is due to the greater distance and angle for the satellite and the atmospheric disturbances. The best isolation is 50 feet (15 meters) or more of concrete or packed dirt, which will effectively block the signal. Underground caves and the subfloors of tall buildings are excellent shields. In the future, I will provide details of electronic shielding that can be constructed using an electric fence charger or large battery charger. Layers are the key for absorbing the microwaves and grounding them electrically. The signals are low voltage, less than 10 millivolts, which make them susceptible to high voltage grounding.

One of the limits of the technology – I am told that if rapid lane changes are made while in a car, the satellite has trouble keeping track. It takes several seconds to recover. Remember that it was designed to track a ballistic missile that does not make rapid sideways movements.

If you are targeted, Dr John Hall recommends using binaural beats or isochronic tones at 7.83 Hz to alleviate some symptoms. The government criminals are using specific tones that are known to be associated with depression, such as approx. 5 to 6 Hz. These are generally used while sleeping. Isochronic tones are best used in a device that cannot be hacked by the criminals. Anything with a battery or a DC current is easy for the criminals to hack. Old CD players that run on a wall plug are good.

### Stratfor Corporation

The Stratfor Corporation is headquartered in Austin, Texas. They were the subject of

investigative journalism by Barrett Brown. Many of the employees are former CIA and FBI agents. The wikileaks Vault 7 files have emails of their employees joking about microwave torture. This is how sick and disturbed these employees have become from working in a system that is so corrupted. See Appendix 2 for the emails joking about microwave torture.

### Corporate Officers

These are the corporate officers of the

These are the corporate officers of the

I have not attempted to cover the drones weapons here, which are just as harmful as the satellite systems. Note that the military just ordered 30,000 drones. Think about that for a minute. Where can you possibly fly 30,000 drones in a war zone? It doesn't make sense. Then you will realize these drones will be used to target civilians all over the world with microwaves. One of my sources told me a story last year, about the drone aircraft that look like miniature fighter jets, following her down the freeway at 65 mph, and hitting her with microwaves. They are real and less expensive than satellites.

## **Conclusions**

This short ebook has described some of the war crimes and Treason being committed by the CIA. The CIA should be abolished by terminating all of its funding. President Kennedy was correct – the CIA should be splintered into a thousand pieces and scattered to the winds.

This document is a living document. The author reserves the right to make corrections and changes.

## **References**

1. Richard Lighthouse, "More Hacking from the Nazi Stasi Academy (NSA)", 2017, smashwords.com and RLighthouse.com; ISBN: 9781370749720.
2. Richard Lighthouse, "NSA & CIA Blocking Distribution of Ebooks," 2017, smashwords.com and RLighthouse.com; ISBN: 9781370874576.
3. Richard Lighthouse, "Installing & Running Detekt: My Experience," 2017, smashwords.com and RLighthouse.com; ISBN: 9781370440542.
4. Richard Lighthouse, "Cell Phone Hacking & the Nazi Stasi Academy" 2016, smashwords.com and RLighthouse.com; ISBN: 9781370681594.

5. Dr Judy Wood, "Where Did the Towers Go?," The New Investigation; 2010.  
DrJudyWood.com

6. Richard Lighthouse, "Targeted Individuals" 2016, smashwords.com and Rlighthouse.com;

7. Richard Lighthouse, "Rockefeller & Rothschild Dirty Money on the London Stock Exchange" 2016, smashwords.com and Rlighthouse.com;

8. Richard Lighthouse, "34 Patents on Subliminal Mind Control" 2017, smashwords.com and Rlighthouse.com;

Acknowledgments: The author gratefully acknowledges Seth, Jane Roberts, and Rob Butts for their significant contributions.

About: The author holds a Master of Science (M.Sc.) degree in Mechanical Engineering from Stanford University and has previously worked for NASA.

Contact: owenc787 at --gmail.com  
Rlight767 -at- yahoo point com  
713.three zero six.8287  
918 West 26<sup>th</sup> Street,  
Houston, Texas, 77008

Funding:

This research was generously supported with a grant from the Foundation Opposed to Academic Puffery (FOAP).

## APPENDIX

I am a proud government whistleblower – see my ebooks about the criminal acts of the CIA and FBI. Readers are advised that the NSA may be blocking or restricting access to some of my ebooks, especially outside the United States. Readers are further advised that digital tracking tags may have been placed in my ebooks. It may be best to download from Apple iBooks, if possible. Note how slowly the jpg's load into the ebook when viewing. The content of some ebooks may have been altered – still trying to monitor this. If you have tried to contact me, it is possible that emails and phone calls are being blocked (Owenc787 at gmail) 713.three.zero.six.8287; 918 West 26<sup>th</sup> Street, Houston, Texas, 77008.

Readers are advised to review the website drjudywood.com which provides compelling evidence about 9-11. <http://drjudywood.com/articles/DEW/StarWarsBeam4.html> ..... Note Figure 63. Dr Wood spent many years researching this and filed suit against the US Government, along with Dr Morgan Reynolds. Jet fuel does not burn through concrete and steel. The cookie-cutter holes were made by a high-powered laser that rapidly ages material - and turned the concrete and steel into dust in seconds. Note Figure 38(a) here: <http://drjudywood.com/articles/DEW/StarWarsBeam3.html> ...Watch the steel beam turn into

dust while standing vertically. This laser operates at a harmonic of the blinking frequency - which causes rapid aging. Readers are also advised to see the movie "Sirius" by Dr Steven Greer, M.D. It is available for free on Netflix, where it is the #1 documentary, and to watch the youtube videos by the Honorable Paul Hellyer, former Canadian Minister of Defense. He has a book titled, "The Money Mafia."

Also, find my brief educational videos on youtube (Some have been blocked from the search engines).

For more than 4 years, this author has been stalked, harassed, and threatened by US Government agents from the CIA, FBI, and NSA - because of the content of these ebooks. My home has been broken into, repeatedly. In May 2014, my girlfriend was drugged and kidnapped from LaGuardia airport. This is not a joke. My computer, phone, and alarm system have been hacked, including those of my friends and family. It is truly sad and pathetic, these agencies have become criminal organizations. If something happens to me (disappearance, false criminal charges, sudden accident, etc. - my readers can be certain that the FBI and CIA were involved. See my related ebooks identifying the murders of Gary Webb, Michael Hastings, Phil Schneider, William Colby, Dr Eugene Mallove, Stan Meyers, and others. In my opinion, the Council on Foreign Relations (CFR) is behind these criminal acts; David Rockefeller was the CEO and Chairman for many years.

The screenshot shows a web browser window displaying the Smashwords dashboard. The URL in the address bar is <https://www.smashwords.com/dashboard/getISBN/732090>. The page title is "ISBN Assignment Results for Treason at the CIA". The main content area displays "Congratulations!" followed by the message "You have assigned an ISBN to your book Treason at the CIA." Below this, a box contains the following information:

<b>ISBN:</b> 9781370074303
<b>Title:</b> Treason at the CIA
<b>Author:</b> Richard Lighthouse
<b>Publisher:</b> Smashwords, Inc.

At the bottom of the page, there is a footer with navigation links: About, Press Room, Blog, Affiliates, FAQ, Support, Privacy Statement, Terms of Service, Jobs, Sign Out. The copyright notice reads "Copyright © 2017 Smashwords, Inc. All rights reserved." The Windows taskbar at the bottom shows the time as 7:38 AM on 6/24/2017.

Figure 9. ISBN for this ebook.



## Appendix 2.

### Stratfor Emails

According to wikileaks "On Monday February 27th, 2012, WikiLeaks began publishing *The Global Intelligence Files*, over five million e-mails from the Texas headquartered "global intelligence" company Stratfor. The e-mails date between July 2004 and late December 2011. They reveal the inner workings of a company that fronts as an intelligence publisher, but provides confidential intelligence services to large corporations, such as Bhopal's Dow Chemical Co., Lockheed Martin, Northrop Grumman, Raytheon and government agencies, including the US Department of Homeland Security, the US Marines and the US Defence Intelligence Agency. The emails show Stratfor's web of informers, pay-off structure, payment laundering techniques and psychological methods."

This is one sample of emails where employees are joking about microwave torture.

[https://wikileaks.org/gifiles/docs/21/2162\\_re-microwave-is-working-again-.html](https://wikileaks.org/gifiles/docs/21/2162_re-microwave-is-working-again-.html)

RE: microwave is working again

Released on 2013-11-15 00:00 GMT

Email-ID

2162

Date

2006-04-12 00:36:54

From

lsimpson@stratfor.com

To

Stratforaustin@stratfor.com, mfriedman@stratfor.com, witters@stratfor.com, gibbons@stratfor.com, gfriedman@stratfor.com, burton@stratfor.com, kuykendall@stratfor.com, parks@stratfor.com, blackburn@stratfor.com

RE: microwave is working again

Ok... As the official keeper of the peeps over the past year, I feel I need to make a statement.

Just because these peeps were brought into this office illegally does not mean that they should be ridiculed and subjected to microwave torture. They are good peeps that quietly assume the roles of office decorations that noone else in the office is willing to do. They have been here a year. This is their home. They deserve.. No.. They have the RIGHT to be here just like the rest of us, and to be offered the same benefits and asylum that we all receive on this side of the office walls.

In fact George, I believe that you should give them jobs!

That is all,

Lee Simpson  
Strategic Forecasting, Inc.  
Quality Assurance Manager  
T: 512-744-4307  
F: 512-744-4334  
lsimpson@stratfor.com  
www.stratfor.com  
=20

-----Original Message-----

From: Don Kuykendall [mailto:kuykendall@stratfor.com]=20  
Sent: Tuesday, April 11, 2006 5:27 PM  
To: Mike Parks; 'John Gibbons'; 'Robin Blackburn'; George Friedman;  
mfriedman@stratfor.com; Fred Burton; Donna Witters;  
Stratforaustin@stratfor.com  
Subject: Re: microwave is working again

Obviously, I need to return to the office SOON.  
Sent via BlackBerry from Cingular Wireless

-----Original Message-----

From: "Mike Parks" <parks@stratfor.com>  
Date: Tue, 11 Apr 2006 18:15:46=20  
To: "'John Gibbons'" <gibbons@stratfor.com>, "'Robin Blackburn'"  
<blackburn@stratfor.com>, "'George Friedman'"  
<gfriedman@stratfor.com>, <mfriedman@stratfor.com>, "'Fred Burton'"  
<burton@stratfor.com>, "'Donna Witters'" <witters@stratfor.com>,  
<Stratforaustin@stratfor.com>  
Subject: RE: microwave is working again

(Whispering) I see dead peeps...

-----Original Message-----

From: John Gibbons [mailto:gibbons@stratfor.com]=20  
Sent: Tuesday, April 11, 2006 6:06 PM  
To: 'Robin Blackburn'; 'George Friedman'; mfriedman@stratfor.com; 'Fred  
Burton'; 'Donna Witters'; Stratforaustin@stratfor.com  
Subject: RE: microwave is working again

Ahh. I miss these long mindless rants. I recall them occurring much more  
frequently in the past. It is nice to see the creativity flowing freely  
again. Spring!=20

John Gibbons  
Strategic Forecasting, Inc.  
Customer Service Manager  
T: 512-744-4305  
F: 512-744-4334  
gibbons@stratfor.com  
www.stratfor.com  
=20

-----Original Message-----

From: Robin Blackburn [mailto:blackburn@stratfor.com]=20  
Sent: Tuesday, April 11, 2006 4:57 PM  
To: 'George Friedman'; mfriedman@stratfor.com; 'Fred Burton'; 'Donna Witters'; Stratforaustin@stratfor.com  
Subject: RE: microwave is working again

And the Peep, never flitting, still is sitting, still is sitting  
On the pallid bust of Pallas just above my chamber door;  
And his eyes have all the seeming of a demon's that is dreaming,  
And the lamp-light o'er him streaming  
throws his shadow on the floor;  
And my soul from out that shadow that lies  
floating on the floor  
Shall be lifted - nevermore!

-- Edgar Allan Peep

-----Original Message-----

From: George Friedman [mailto:gfriedman@stratfor.com]  
Sent: Tuesday, April 11, 2006 4:52 PM  
To: mfriedman@stratfor.com; 'Fred Burton'; 'Donna Witters';  
Stratforaustin@stratfor.com  
Subject: RE: microwave is working again

Last night I saw upon the stairs a little peep who wasn't there.=20

-----Original Message-----

From: Meredith Friedman [mailto:mfriedman@stratfor.com]=20  
Sent: Tuesday, April 11, 2006 4:50 PM  
To: Fred Burton; 'George Friedman'; 'Donna Witters';  
Stratforaustin@stratfor.com  
Subject: Re: microwave is working again

Found a peep who is not really a peep\_ appears to be a double peep.

--

Sent via BlackBerry from Cingular Wireless

-----Original Message-----

From: "Fred Burton" <burton@stratfor.com>  
Date: Tue, 11 Apr 2006 16:44:04=20

To: "George Friedman" <gfriedman@stratfor.com>, "Donna Witters" <witters@stratfor.com>, <Stratforaustin@stratfor.com>  
Subject: RE: microwave is working again

Investigation underway.  
=A0=20

I am standing on a peep neck and will feed one to my Ridgeback tonight.  
=A0=20  
=A0=20  
=20

-----  
From: George Friedman [mailto:gfriedman@stratfor.com]  
Sent: Tuesday, April 11, 2006 4:41 PM  
To: 'Fred Burton'; 'Donna Witters'; Stratforaustin@stratfor.com  
Subject: RE: microwave is working again

=20  
=20  
Check the Peeps. One of them may be a plant.  
=20  
=20

-----  
From: Fred Burton [mailto:burton@stratfor.com]  
Sent: Tuesday, April 11, 2006 4:41 PM  
To: 'Donna Witters'; Stratforaustin@stratfor.com  
Subject: RE: microwave is working again

=20  
=20  
Any suspected peep sympathizers or underground efforts to insert peeps amongst us will come under intense security scrutiny.  
=A0=20  
=20  
=20

-----  
From: Donna Witters [mailto:witters@stratfor.com]  
Sent: Tuesday, April 11, 2006 4:38 PM  
To: Stratforaustin@stratfor.com  
Subject: RE: microwave is working again

=20  
=20  
let this be a lesson to today's peepnappers. the microwave has been restored to be used for its proper purpose, which does not include any form of peep abuse. next time anyone considers absconding with any of the pastel refugees located within the borders of the peep protection zone, it could be much, much worse.  
=20  
=A0=20

=A0=20

=20

-----  
From: Jeremy Edwards [mailto:edwards@stratfor.com]

Sent: Tuesday, April 11, 2006 4:23 PM

To: 'Leticia Gonzalez'; Stratforaustin@stratfor.com

Subject: RE: microwave is working again

=20

=20

=20

A black day for the peeps of the world. But very sunshiny indeed for everyone who needs to heat their lunch up.

=20

=A0

=20

=20

Jeremy Edwards

=20

Strategic Forecasting, Inc.

=20

Writer/Copyeditor

=20

T: 512-744-4321

=20

F: 512-744-4434

=20

edwards@stratfor.com

=20

www.stratfor.com: <<http://www.stratfor.com>> =A0

=20

=A0

=20

=A0

=20